

## Technical Information

### STG700 SmartLine Gauge Pressure Specification 34-ST-03-122, November 2016



#### Introduction

Part of the SmartLine® family of products, the STG700 Dual Head and STG700 Inline are suitable for monitoring, control and data acquisition. STG700 Dual Head products feature piezoresistive sensor technology combining pressure sensing with on chip temperature compensation capabilities providing high accuracy, stability and performance over a wide range of application pressures and temperatures. The SmartLine family is also fully tested and compliant with Experion® PKS providing the highest level of compatibility assurance and integration capabilities. SmartLine easily meets the most demanding application needs for pressure measurement applications.

#### Best in Class Features:

- Accuracy up to 0.065 % of calibrated span
- Stability up to 0.025% of URL per year for five years
- Automatic temperature compensation
- Rangeability up to 100:1
- Response times as fast as 100ms
- Easy to use and intuitive display capabilities
- Intuitive External zero & span capability
- On-board diagnostic capabilities
- Integral Dual Seal design for safety based on ANSI/NFPA 70-202 and ANSI/ISA 12.27.0
- Full compliance to SIL 2/3 requirements as a standard.

#### Communications/Output Options:

- HART® (version 7.0)



Figure 1 – STG700 Dual Head and Inline Gauge Pressure Transmitters

#### Span & Range Limits:

Model	URL/Max Span psi (bar)	LRL psi (bar)	Min Span	Turn down
STG735/STG73S	50 (3.5)	-14.7 (-1.0)	0.5 (0.035)	100:1
STG745/STG74S	500 (35)	-14.7 (-1.0)	5 (.35)	100:1
STG775/STG77S	3000 (210)	-14.7 (-1.0)	30 (2.1)	100:1
STG78S	6000 (420)	-14.7 (-1.0)	60 (4.2)	100:1
STG79S	10000 (690)	-14.7 (-1.0)	100 (6.9)	100:1

## Description

The SmartLine family pressure transmitters are designed around a high performance piezo-resistive sensor. This one sensor actually integrates multiple sensors linking process pressure measurement with on-board static pressure (GP Models) and temperature compensation measurements.

## Indication/Display Option

### Standard LCD Display Features

- Modular (may be added or removed in the field)
- Supports HART protocol variant
- 0, 90, 180, & 270 degree position adjustments
- Configurable (HART only) and standard (Pa, KPa, MPa, KGcm<sup>2</sup>, Torr, ATM, inH<sub>2</sub>O, mH<sub>2</sub>O, bar, mbar, inHG, FTH<sub>2</sub>O, mmH<sub>2</sub>O, mm HG, & psi) measurement units.
- 2 Lines 6 digits PV (9.95H x 4.20W mm) 8 Characters
- Square root output indication ( $\sqrt{\quad}$ ) and Write protect Indication
- Built in Basic Device Configuration through Internal or External Buttons – Range/Engineering Unit/Loop Test /Loop Calibration/Zero /Span Setting

## Diagnostics

SmartLine transmitters all offer digitally accessible diagnostics which aid in providing advanced warning of possible failure events minimizing unplanned shutdowns, providing **lower overall operational costs**

## System Integration

- SmartLine communications protocols all meet the most current published standards for HART.
- All ST 700 units are Experion tested to provide the highest level of compatibility assurance

## Configuration Tools

### External Two Button Configuration Option

Suitable for all electrical and environmental requirements, SmartLine offers the ability to configure the transmitter and display, for all basic parameters, via two externally accessible buttons when a display option is selected. Zero/span capabilities are also optionally available via two external buttons with or without selection of the display option.

### Internal Two Button Configuration Option

The Standard display has two buttons that can be used for Basic configuration such as re ranging, PV Engineering unit setting, Zero/Span settings, Loop testing and calibration functions.

### Hand Held Configuration

SmartLine transmitters feature two-way communication and configuration capability between the operator and the transmitter. This is accomplished via Honeywell's field-rated Multiple Communication Configurator (MCT404). The MCT404 is capable of field configuring HART Devices and can also be ordered for use in intrinsically safe environments. All Honeywell transmitters are designed and tested for compliance with the offered communication protocols and are designed to operate with any properly validated hand held configuration device.

### Personal Computer Configuration

Field Device Manager (FDM) Software and FDM Express are also available for managing HART device configurations.

## Modular Design

To help contain maintenance & inventory costs, all ST 700 transmitters are modular in design supporting the user's ability to replace meter bodies, standard displays or electronic modules without affecting overall performance. Each meter body is uniquely characterized to provide intolerance performance over a wide range of application variations in temperature and pressure.

### Modular Features

- Meter body replacement
- Add or remove standard displays
- Add or remove lightning protection (terminal connection)

With no performance effects, *Honeywell's unique modularity results in lower inventory needs and lower overall operating costs.*

**Performance Specifications**

**Reference Accuracy:** (conformance to +/-3 Sigma)

**Table 1**

	Model	URL	LRL	Min Span	Maximum Turndown Ratio	Stability (% URL/Year for five years)	Reference Accuracy (% Span) <sup>1,2</sup>
<b>Standard Accuracy</b>	STG735	50 psi (3.5 bar)	-14.7 psi (-1.0 bar)	0.5 psi (.035 bar)	100:1	0.025%	0.0650%
	STG73S	50 psi (3.5 bar)	-14.7 psi (-1.0 bar)	0.5 psi (.035 bar)			
	STG745	500 psi (35 bar)	-14.7 psi (-1.0 bar)	5 psi (.35 bar)			
	STG74S	500 psi (35 bar)	-14.7 psi (-1.0 bar)	5 psi (.35 bar)			
	STG775	3000 psi (210 bar)	-14.7 psi (-1.0 bar)	30 psi (2.1 bar)			
	STG77S	3000 psi (210 bar)	-14.7 psi (-1.0 bar)	30 psi (2.1 bar)			
	STG78S	6000 psi (420 bar)	-14.7 psi (-1.0 bar)	60 psi (4.2 bar)			
	STG79S	10000 psi (690 bar)	-14.7 psi (-1.0 bar)	100 (6.9 bar)			

Zero and span may be set anywhere within the listed (URL/LRL) range limits

**Accuracy, Span and Temperature Effect:** (Conformance to +/-3 Sigma)

**Table 2**

	Model	URL	Accuracy <sup>1,2</sup> (% of Span)			Temperature Effect (% Span/50°F)		
			For Turndowns Greater Than	A	B	C psi (bar)	D	E
<b>Standard Accuracy</b>	STG735	50 psi (3.5 bar)	17:1	0.025	0.04	3 (0.2)	0.070	0.008
	STG73S	50 psi (3.5 bar)	8:1			6 (0.4)	0.100	0.015
	STG745	500 psi (35 bar)	20:1			25 (1.7)	0.075	0.013
	STG74S	500 psi (35 bar)	14:1			35 (2.4)	0.100	0.020
	STG775	3000 psi (210 bar)	9:1			350 (24.1)	0.075	0.013
	STG77S	3000 psi (210 bar)	8:1			400 (27.6)	0.100	0.025
	STG78S	6000 psi (420 bar)	10:1			600 (41.4)	0.100	0.070
	STG79S	10000 psi (690 bar)	8:1			1200 (82.7)	0.200	0.170

**Total Performance (% of Span):**

**Total Performance Calculation:** =  $\sqrt{(Accuracy)^2 + (Temperature Effect)^2}$

**Total Performance Examples (for**

**comparison):** @ 5:1 Turndown, +/-50 °F (28°C) shift

- STG735 @ 10 psi:** 0.128% of span
- STG745 @ 100 psi:** 0.154% of span
- STG775 @ 600 psi:** 0.154 % of span
- STG78S @ 1200 psi:** 0.455% of span

- STG73S @ 10 psi:** 0.187% of span
- STG74S @ 100 psi:** 0.210% of span
- STG77S @ 600 psi:** 0.234% of span
- STG79S @ 2000 psi:** 1.052% of span

Turn Down Effect	Temp Effect
$\pm \left[ A + B \left( \frac{C}{\% \text{ Span}} \right) \right]$	$\pm \left[ + \left( \frac{URL}{\% \text{ Span per } 28^\circ\text{C (50}^\circ\text{F)}} \right) \right]$

+/-

**Typical Calibration Frequency:**

Calibration verification is recommended every two (2) years

**Notes:**

1. Terminal Based Accuracy - Includes combined effects of linearity, hysteresis, and repeatability. Analog output adds 0.006% of span.
2. For zero based spans and reference conditions of: 25 °C (77 °F) for LRV >= 0 psia, 10 to 55% RH, and 316 Stainless Steel barrier diaphragm.

**Operating Conditions – All Models**

Parameter	Reference Condition		Rated Condition		Operative Limits		Transportation and Storage	
	°C	°F	°C	°F	°C	°F	°C	°F
Ambient Temperature <sup>1</sup>	25±1	77±2	-40 to 85	-40 to 185	-40 to 85	-40 to 185	-55 to 120	-67 to 248
Meter Body Temperature	25±1	77±2	-40 to 110	-40 to 230	-40 to 125	-40 to 257	-55 to 120	-67 to 248
Humidity %RH	10 to 55		0 to 100		0 to 100		0 to 100	
Vac. Region – Min. Pressure mmHg absolute inH <sub>2</sub> O absolute	Atmospheric Atmospheric		25 13		2 (short term) <sup>2</sup> 1 (short term) <sup>2</sup>			
Supply Voltage	10.8 to 42.4 Vdc at terminals							
Load Resistance	0 to 1,440 ohms (as shown in Figure 2)							
Maximum Allowable Working Pressure (MAWP) <sup>3, 4</sup> <small>(ST700 products are rated to Maximum Allowable Working Pressure. MAWP depends on Approval Agency and transmitter materials of construction.)</small>	STG735: 50 psi (3.5 bar)		STG73S: 50 psi (3.5 bar)		STG74S: 500 psi (35 bar)		STG77S: 3000 psi (210 bar)	
	STG745: 500 psi (35 bar)		STG74S: 500 psi (35 bar)		STG77S: 3000 psi (210 bar)		STG78S: 6000 psi (420 bar)	
	STG775: 3000 psi (210 bar)		STG77S: 3000 psi (210 bar)		STG78S: 6000 psi (420 bar)		STG79S: 10000 psi (690 bar)	

<sup>1</sup> LCD Display operating temperature -20°C to +70°C Storage temperature -30°C to 80°C.

<sup>2</sup> Short term equals 2 hours at 70°C (158°F)

<sup>3</sup> Units can withstand overpressure of 1.5 x MAWP without damage

<sup>4</sup> Consult the factory for MAWP of ST 700 transmitters with CRN approval

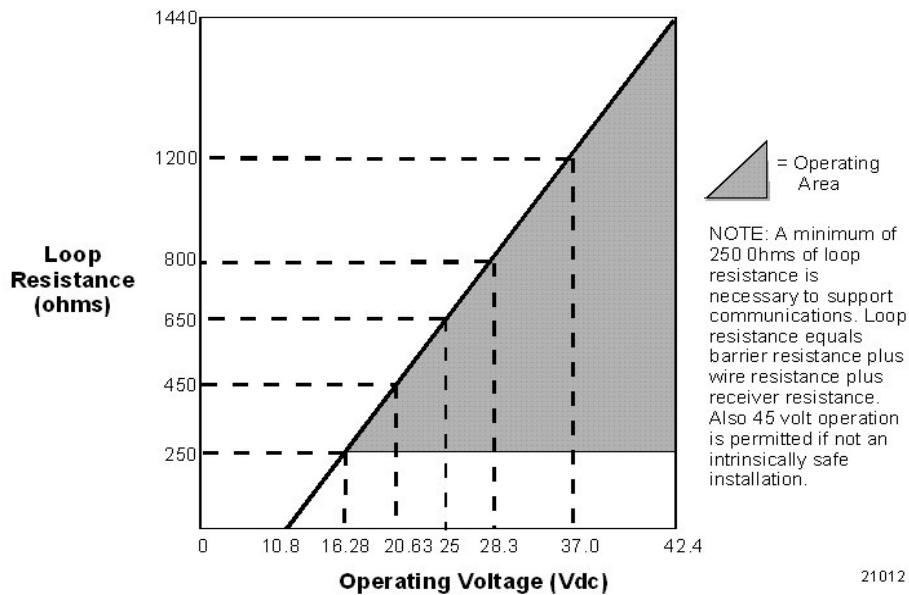

**Figure 2 - Supply voltage and loop resistance chart & calculations**

**Performance Under Rated Conditions – All Models**

Parameter	Description									
<b>Analog Output</b> <b>Digital Communications:</b>	Two-wire, 4 to 20 mA HART7									
<b>HART Output Failure Modes</b>	<table> <tr> <td><b>Normal Limits:</b></td> <td><b>Honeywell Standard:</b></td> <td><b>NAMUR NE 43 Compliance:</b></td> </tr> <tr> <td></td> <td>3.8 – 20.8 mA</td> <td>3.8 – 20.5 mA</td> </tr> <tr> <td><b>Failure Mode:</b></td> <td>≤ 3.6 mA and ≥ 21.0 mA</td> <td>≤ 3.6 mA and ≥ 21.0 mA</td> </tr> </table>	<b>Normal Limits:</b>	<b>Honeywell Standard:</b>	<b>NAMUR NE 43 Compliance:</b>		3.8 – 20.8 mA	3.8 – 20.5 mA	<b>Failure Mode:</b>	≤ 3.6 mA and ≥ 21.0 mA	≤ 3.6 mA and ≥ 21.0 mA
<b>Normal Limits:</b>	<b>Honeywell Standard:</b>	<b>NAMUR NE 43 Compliance:</b>								
	3.8 – 20.8 mA	3.8 – 20.5 mA								
<b>Failure Mode:</b>	≤ 3.6 mA and ≥ 21.0 mA	≤ 3.6 mA and ≥ 21.0 mA								
<b>Supply Voltage Effect</b>	0.005% span per volt.									
<b>Transmitter Turn on Time</b> (includes power up & test algorithms)	2.5 sec									
<b>Response Time</b> (delay + time constant)	100ms									
<b>Damping Time Constant</b>	Adjustable from 0 to 32 seconds in 0.1 increments. <b>Default Value:</b> 0.5 seconds									
<b>Vibration Effect:</b>	Less than +/- 0.1% of URL w/o damping Per IEC60770-1 field or pipeline, high vibration level (10-2000Hz: 0.21 displacement/3g max acceleration)									
<b>Electromagnetic Compatibility</b>	IEC 61326-3-1									
<b>Lightning Protection Option</b>	<b>Leakage Current:</b> 10uA max @ 42.4VDC 93C <b>Impulse rating:</b> 8/20uS      5000A (>10 strikes)      10000A (1 strike min.) 10/1000uS    200A (> 300 strikes)									

**Materials Specifications** (see model selection guide for availability/restrictions with various models)

Parameter	Description
<b>Barrier Diaphragms Material</b>	<b>STG700 Dual Head:</b> 316L SS, Hastelloy® C-276 <sup>2</sup> <b>STG700 Inline:</b> 316L SS, Hastelloy® C-276 <sup>2</sup>
<b>Process Head Material</b>	<b>STG700 Dual Head:</b> Carbon Steel (Zinc Plated) <sup>5</sup> , 316 SS <sup>4</sup> , Hastelloy® C-276 <sup>6</sup> <b>STG700 Inline:</b> 316L SS, Hastelloy® C-276 <sup>6</sup>
<b>Vent/Drain Valves &amp; Plugs</b> <sup>1</sup>	<b>STG700 Dual Head:</b> 316 SS <sup>4</sup> , Hastelloy® C-276 <sup>2</sup> <b>STG700 Inline:</b> N/A
<b>Head Gaskets</b>	<b>STG700 Dual Head:</b> Glass-filled PTFE standard. Viton® and graphite are optional. <b>STG700 Inline:</b> N/A
<b>Meter Body Bolting</b>	<b>STG700 Dual Head:</b> Carbon Steel (Zinc plated) standard. Options include 316 SS, NACE A286 SS bolts and nuts or NACE A286 SS bolts and 304 SS nuts, and Super Duplex. <b>STG700 Inline:</b> N/A
<b>Mounting Bracket</b>	Carbon Steel (Zinc-plated) or 304 or 316 Stainless Steel, See Figures 4 & 5
<b>Fill Fluid</b>	Silicone, CTFE
<b>Electronic Housing</b>	Pure Polyester Powder Coated Low Copper (<0.4%)-Aluminum. Meets NEMA 4X, IP66, IP67 and NEMA 7 (explosion proof). All stainless steel housing is optional.
<b>Process Connections</b>	<b>STG700 Dual Head:</b> ½ -inch NPT(female) <b>STG700 Inline:</b> ½ -inch NPT(female), ½ -inch NPT male, 9/16 Aminco, G½ -B Male Thread
<b>Wiring</b>	Accepts up to 16 AWG (1.5 mm diameter).
<b>Dimensions</b>	See <a href="#">Figure 3</a> and <a href="#">Figure 4</a>
<b>Net Weight</b>	<b>STG700 Dual Head:</b> 8.3 pounds (3.8 Kg). <b>STG700 Inline:</b> 3.6 pounds (1.6 Kg) with Aluminum Housing

<sup>1</sup> Vent/Drains are sealed with Teflon®<sup>2</sup> Hastelloy® C-276 or UNS N10276<sup>4</sup> Supplied as 316 SS or as Grade CF8M, the casting equivalent of 316 SS.<sup>5</sup> Carbon Steel heads are zinc-plated and not recommended for water service due to hydrogen migration. For that service, use 316 stainless steel wetted Process Heads.<sup>6</sup> Hastelloy® C-276 or UNS N10276. Supplied as indicated or as Grade CW12MW, the casting equivalent of Hastelloy® C-276

## Communications Protocols & Diagnostics

### HART Protocol

#### Version:

HART 7

#### Power Supply

Voltage: 10.8 to 42.4Vdc at terminals

Load: Maximum 1440 ohms See [Figure 2](#)

Minimum Load: 0 ohms. (For handheld communications a minimum load of 250 ohms is required)

### Standard Diagnostics

ST 700 top level diagnostics are reported as either critical or non-critical and readable via the DD/DTM tools or integral display as shown.

#### Critical Diagnostics

HART DD/DTM Tools	Standard Display
Electronic Module DAC Failure	Fault Comm EI
Meter Body NVM Corrupt	Fault Mtrbody
Config. Data Corrupt	Fault Comm EI
Electronic Module Diag Failure	Fault Comm EI
Meter Body Critical Failure	Fault Mtrbody
Sensor Comms Timeout	Fault Mbd Com

#### Non-Critical Diagnostics

HART DD/DTM Tools
Display Failure
Electronic Module Comm Failure
Meter Body Excess Correct
Sensor Over Temperature
Fixed Current Mode
PV Out of Range
No Factory Calibration
LRV Set Error – Zero Config. Button
URV Set Error – Zero Config. Button
AO Out of Range
Loop Current Noise
Meter Body Unreliable Comm
No DAC Calibration
Sensor Supply Voltage Low

Refer to ST 700 manuals for additional level diagnostic information.

**Approval Certifications:**

AGENCY	TYPE OF PROTECTION	FIELD PARAMETERS	AMBIENT TEMP (Ta)
FM Approvals™	<b>Explosionproof:</b> Class I, Division 1, Groups A, B, C, D; <b>Dust Ignition Proof:</b> Class II, III, Division 1, Groups E, F, G;  Class I, Zone 0/1, AEx d IIC Ga/Gb Class II, Zone 21, AEx tb IIIC Db T 95°C	Note 1	T5: -50 °C to 85°C T6: -50 °C to 65°C
	<b>Intrinsically Safe:</b> Class I, II, III, Division 1, Groups A, B, C, D, E, F, G  Class I, Zone 0, AEx ia IIC Ga		T4: -50 °C to 70°C
	<b>Nonincendive:</b> Class I, Division 2, Groups A, B, C, D locations,  Class I, Zone 2, AEx nA IIC Gc	Note 1	T4: -50 °C to 85°C
	<b>Enclosure:</b> Type 4X/ IP66/ IP67	All	-
Canadian Standards Association (CSA)	<b>Explosion Proof:</b> Class I, Division 1, Groups A, B, C, D; <b>Dust Ignition Proof:</b> Class II, III, Division 1, Groups E, F, G;  Ex d IIC Ga Ex tb IIIC Db T 95°C	Note 1	T5: -50 °C to 85°C T6: -50 °C to 65°C
	<b>Intrinsically Safe:</b> Class I, II, III, Division 1, Groups A, B, C, D, E, F, G  Ex ia IIC Ga		T4: -50 °C to 70°C
	<b>Nonincendive:</b> Class I, Division 2, Groups A, B, C, D; T4  Ex nA IIC Gc	Note 1	T4: -50 °C to 85°C
	<b>Enclosure:</b> Type 4X/ IP66/ IP67	All	-
ATEX	<b>Flameproof:</b> II 1/2 G Ex d IIC Ga/Gb II 2 D Ex tb IIIC Db T 95°C	Note 1	T5: -50 °C to 85°C T6: -50 °C to 65°C
	<b>Intrinsically Safe:</b> II 1 G Ex ia IIC Ga		T4: -50 °C to 70°C
	<b>Nonincendive:</b> II 3 G Ex nA IIC Gc	Note 1	T4: -50 °C to 85°C
	<b>Enclosure:</b> IP66/ IP67	All	-

**Approval Certifications: (Continued)**

<b>IECEX (World)</b>	<b>Flameproof :</b> Ex d IIC Ga/Gb Ex tb IIIC Db T 95°C	Note 1	T5: -50 °C to 85°C T6: -50 °C to 65°C
	<b>Intrinsically Safe:</b> Ex ia IIC Ga		T4: -50 °C to 70°C
	<b>Nonincendive:</b> Ex nA IIC Gc	Note 1	T4: -50 °C to 85°C
	<b>Enclosure:</b> IP66/ IP67	All	-
<b>NEPSI (China)</b>	<b>Flameproof:</b> Ex d IIC Ga/Gb Ex tb IIIC Db T 85°C	Note 1	T5: -50 °C to 85°C T6: -50 °C to 65°C
	<b>Intrinsically Safe:</b> Ex ia IIC Ga		T4: -50 °C to 70°C
	<b>Nonincendive:</b> Ex nA IIC Gc	Note 1	T4: -50 °C to 85°C
	<b>Enclosure :</b> IP 66/67	All	-

**Notes:**

- Operating Parameters:  
Voltage= 11 to 42 V DC      Current= 4-20 mA Normal

**Other Certification Options****Materials**

- NACE MRO175, MRO103, ISO15156

<b>SIL 2/3 Certification</b>	IEC 61508 SIL 2 for non-redundant use and SIL 3 for redundant use according to EXIDA and TÜV Nord Sys Tec GmbH & Co. KG under the following standards: IEC61508-1: 2010; IEC 61508-2: 2010; IEC61508-3: 2010.
------------------------------	---



**Mounting & Dimensional Drawings**

Reference Dimensions:  $\frac{\text{millimeters}}{\text{inches}}$

**Mounting Configurations: (Dual head design)**

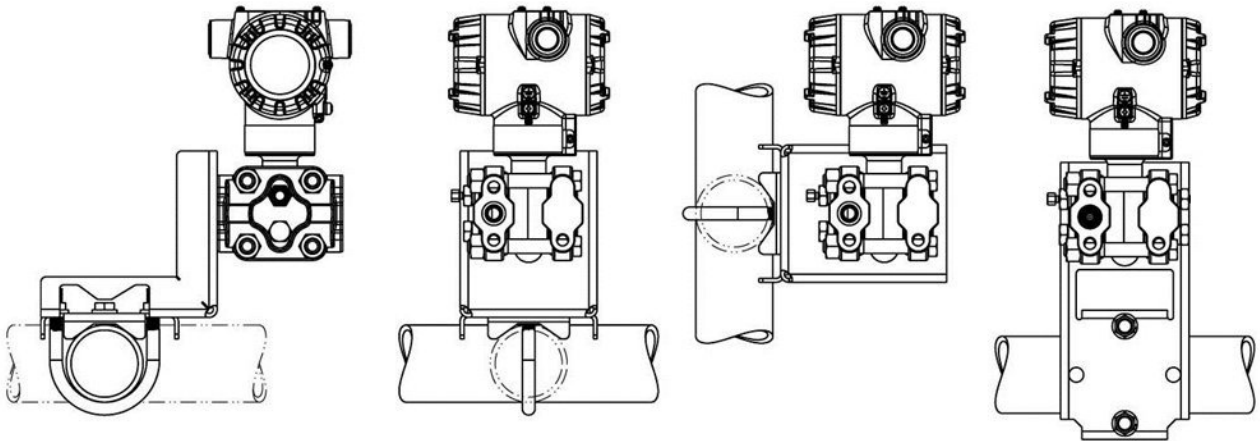

**Dimensions: (Dual head design)**

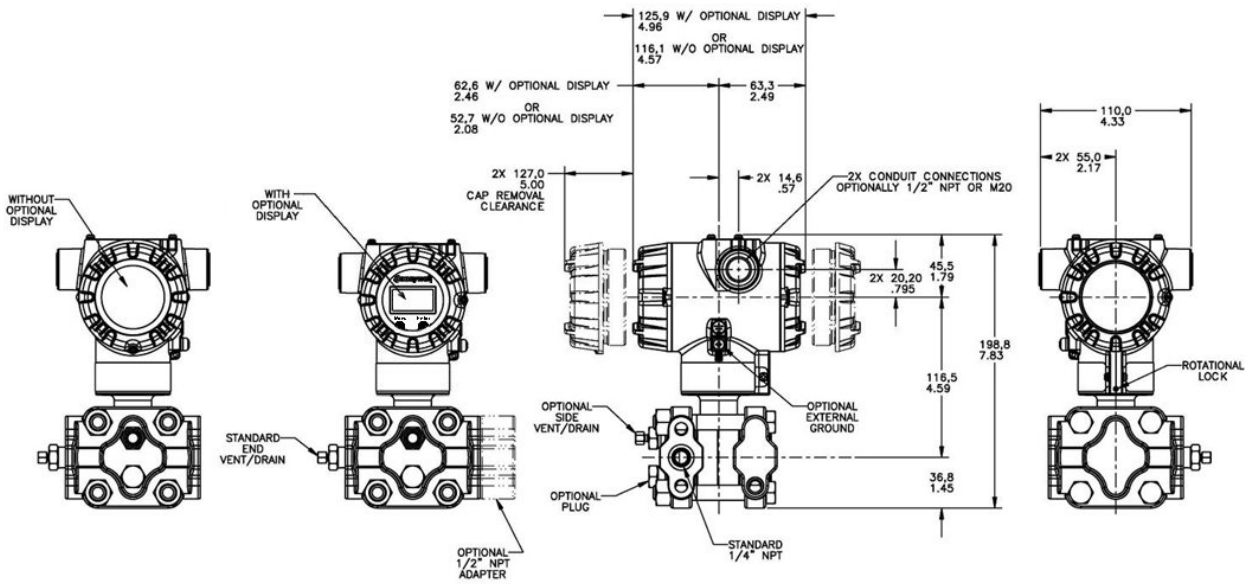

**Figure 3 – Typical mounting dimensions of STG735, STG745 & STG775 for reference**

Reference Dimensions:  $\frac{\text{millimeters}}{\text{inches}}$

**Mounting Configurations (Inline Designs)**

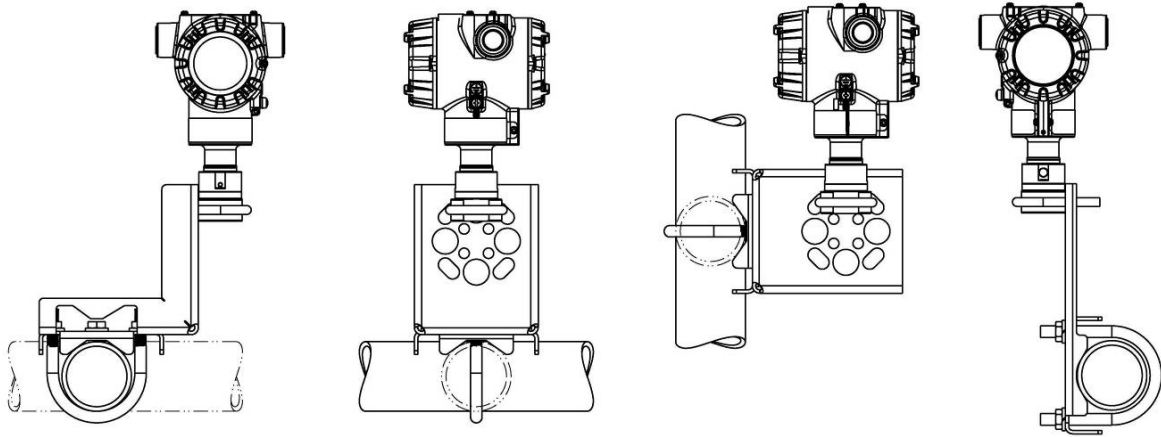

**Dimension (Inline Design)**

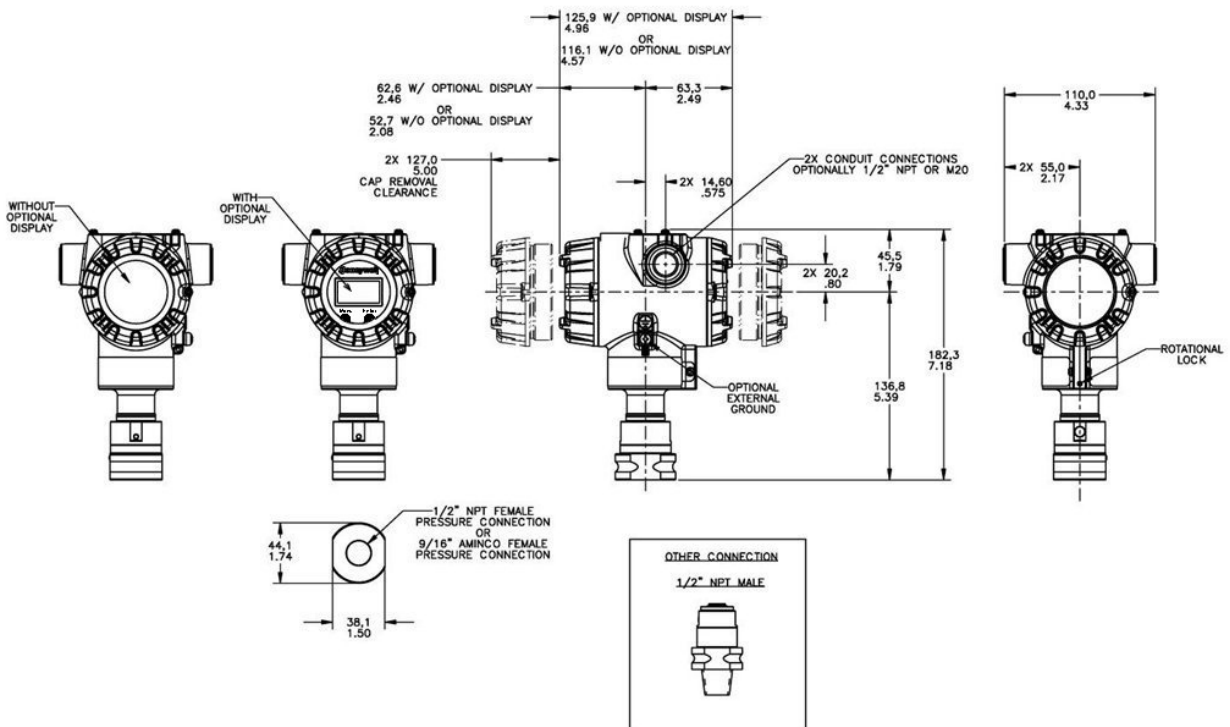

Figure 4 – Typical mounting dimensions of STG74S, STG77S, STG78S, & STG79S for reference

Model Selection Guides are subject to change and are inserted into the specifications as guidance only. Prior to specifying or ordering a model check for the latest revision Model Selection Guides which are published at: [www.honeywellprocess.com/en-US/pages/default.aspx](http://www.honeywellprocess.com/en-US/pages/default.aspx)

**Model Selection Guide**

**Model STG700  
Gauge Pressure Transmitters**

Model Selection Guide  
34-ST-16-122 Issue 1

**Instructions:** Make selections from all Tables using column below the proper arrow. Asterisk indicates availability. Letter (a) refers to restrictions highlighted in the restrictions table. Tables delimited with dashes.

Key                      I                      II                      III                      IV                      V                      VI                      VII                      VIII                      IX

STG7\_\_ - \_\_\_\_\_ - \_\_\_ - \_\_\_ - \_\_\_\_\_ - \_\_\_\_\_ - \_\_\_\_\_ - \_\_\_\_\_ - \_\_\_\_\_ - 0000

KEY NUMBER	URL/Max Span	LRL	Min Span	Units
Gauge Dual Head	50 (3.5)	-14.7 (-1.0)	0.5 (.035)	psi (bar)
	500 (35)	-14.7 (-1.0)	5 (.35)	psi (bar)
	3000 (210)	-14.7 (-1.0)	30 (2.1)	psi (bar)
Gauge In-Line	50 (3.5)	-14.7 (-1.0)	0.5 (.035)	psi (bar)
	500 (35)	-14.7 (-1.0)	5 (.35)	psi (bar)
	3000 (210)	-14.7 (-1.0)	30 (2.1)	psi (bar)
	6000 (420)	-14.7 (-1.0)	60 (4.2)	psi (bar)
	10000 (690)	-14.7 (-1.0)	100 (6.9)	psi (bar)

Selection	Availability			
STG735	↓			
STG745	↓			
STG775		↓		
STG73S			↓	
STG74S			↓	
STG77S				↓
STG78S				↓
STG79S				↓

TABLE I		METER BODY SELECTIONS			
a. Process Head & Diaphragm Materials	Process Head/Reference Head Material <sup>1b</sup>		Barrier Diaphragm Material		
	Plated Carbon Steel		316L SS Hastelloy <sup>®</sup> C - 276		
	316 Stainless Steel		316L SS Hastelloy C - 276		
	Hastelloy C - 276/316 Stainless Steel		Hastelloy C - 276		
b. Fill Fluid	Silicone Oil 200 Fluorinated Oil CTFE				
c. Process Connection	Size/Type		Material		
	9/16" Aminco		Same as Process Head		
	1/2" NPT (female)		Same as Process Head <sup>1a</sup>		
	1/2" NPT (male)		Same as Process Head		
G 1/2 B Threaded Fitting		Same as Process Head			
d. Bolt/Nuts Materials	None				
	Carbon Steel				
	316 SS				
	Grade 660 (NACE A286) with NACE 304 SS Nuts				
	Grade 660 (NACE A286) Bolts & Nuts Super Duplex				
e. Vent/Drain Type/Location	Head Type	Vent Type	Location	Vent Material	
	None	None	None	None	
	Single Ended	None	None	None	
	Single Ended	Standard Vent	Side	Matches Head Material <sup>1</sup>	
	Single Ended	Center Vent	Side	Stainless Steel Only	
	Dual Ended	Standard Vent	End	Matches Head Material <sup>1</sup>	
	Dual Ended	Center Vent	End	Stainless Steel only	
Dual Ended	Std Vent/Plug	Side/End	Matches Head Material <sup>1</sup>		
f. Gasket Materials	None				
	Teflon <sup>®</sup> or PTFE (Glass Filled)				
	Viton <sup>®</sup>				
	Graphite				

A _____	*	*			
B _____	*	*			
E _____	*	*	*	*	*
F _____	*	*	*	*	*
J _____	*	*	*	*	*
_1_____	*	*	*	*	*
_2_____	*	*	*	*	*

__A__			*	*	*
__G__	*	*	*	*	*
__H__			*	*	*
__B__			*	*	*
__0__			*	*	*
__C__	*	*			
__S__	*	*			
__N__	*	*			
__K__			p	p	
__D__			p	p	

__0__			*	*	*
__1__	*	*			
__2__	*	*			
__3__			t	t	
__4__	*	*			
__5__			t	t	
__6__	*	*			
__0__			*	*	*
__A__	*	*			
__B__	*	*			
__C__	*	*			

<sup>1</sup> Except Carbon Steel Heads shall use 316SS Vent/Drain & Plugs and or 1/2" adapters  
<sup>1a</sup> STG735,745,775 supplied via 1/2" flange adapter same material as process head except carbon steel shall use 316 SS  
<sup>1b</sup> Reference head available with Dual Head Gage models only. In-Line Gage models are supplied with Process Head only.

<b>STANDARD</b>	<b>REVERSED 90°/STANDARD</b>
<b>SELECTION 1<sup>4</sup></b>	<b>SELECTION 2 SELECTION 3</b>

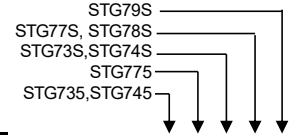
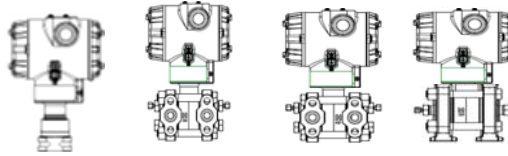

TABLE II Meter Body & Connection Orientation		
Head/Connect Orientation	Standard	High Side Left, Ref Side Right <sup>2</sup> / Std Head Orientation
	Reversed	Ref Side Left, High Side Right <sup>2</sup>
	90/Standard	High Side Left, Ref Side Right <sup>2</sup> / 90° Head Rotation

1	*	*	*	*	*
2	*	*			
3	<b>h</b>	<b>h</b>			

TABLE III AGENCY APPROVALS	
Approvals	No Approvals Required
	<FM> Explosion proof, Intrinsically Safe, Non-incendive, & Dustproof
	CSA Explosion proof, Intrinsically Safe, Non-incendive, & Dustproof
	ATEX Explosion proof, Intrinsically Safe & Non-incendive
	IECEx Explosion proof, Intrinsically Safe & Non-incendive
	NEPSI Explosion proof, Intrinsically Safe & Non-incendive

0	*	*	*	*	*
A	*	*	*	*	*
B	*	*	*	*	<b>p</b>
C	*	*	*	*	*
D	*	*	*	*	*
G	*	*	*	*	*

TABLE IV TRANSMITTER ELECTRONICS SELECTIONS			
a. Electronic Housing Material & Connection Type	Material	Connection	Lightning Protection
	Polyester Powder Coated Aluminum	1/2 NPT	None
	Polyester Powder Coated Aluminum	M20	None
	Polyester Powder Coated Aluminum	1/2 NPT	Yes
	Polyester Powder Coated Aluminum	M20	Yes
	316 Stainless Steel (Grade CF8M)	1/2 NPT	None
	316 Stainless Steel (Grade CF8M)	M20	None
	316 Stainless Steel (Grade CF8M)	1/2 NPT	Yes
	316 Stainless Steel (Grade CF8M)	M20	Yes
b. Output/ Protocol	Analog Output		Digital Protocol
	4-20mA dc		HART Protocol
c. Customer Interface Selections	Indicator	Ext Zero, Span & Config Buttons	Languages
	None	None	None
	None	Yes (Zero/Span Only)	None
	Standard (w/Internal Zero, Span & Config buttons)	None	EN
	Standard (w/Internal Zero, Span & Config buttons)	Yes	EN

A__	*	*	*	*	*
B__	*	*	*	*	*
C__	*	*	*	*	*
D__	*	*	*	*	*
E__	*	*	*	*	*
F__	*	*	*	*	*
G__	*	*	*	*	*
H__	*	*	*	*	*

_H_	*	*	*	*	*
-----	---	---	---	---	---

__0	*	*	*	*	*
__A	*	*	*	*	*
__S	*	*	*	*	*
__T	*	*	*	*	*

TABLE V CONFIGURATION SELECTIONS			
a. Application Software	Diagnostics		
	Standard Diagnostics		
b. Output Limit, Failsafe & Write Protect Settings	Write Protect	Fail Mode	High & Low Output Limits <sup>3</sup>
	Disabled	High > 21.0mA dc	Honeywell Std (3.8 - 20.8 mA dc)
	Disabled	Low < 3.6mA dc	Honeywell Std (3.8 - 20.8 mA dc)
	Enabled	High > 21.0mA dc	Honeywell Std (3.8 - 20.8 mA dc)
Enabled	Low < 3.6mA dc	Honeywell Std (3.8 - 20.8 mA dc)	
c. General Configuration	General Configuration		
	Factory Standard Custom Configuration (Unit Data Required from customer)		

1__	*	*	*	*	*
-----	---	---	---	---	---

_1_	*	*	*	*	*
_2_	*	*	*	*	*
_3_	*	*	*	*	*
_4_	*	*	*	*	*

__S	*	*	*	*	*
__C	*	*	*	*	*

<sup>2</sup> Left side/Right side as viewed from the customer connection perspective

<sup>3</sup> NAMUR Output Limits are configurable by customer

<sup>4</sup> Process connections will vary on In-Line Models

TABLE VI CALIBRATION & ACCURACY SELECTIONS			
a. Accuracy and Calibration	Accuracy		Calibration Qty
	Standard	Factory Standard	Single Calibration
	Standard	Custom (Unit Data Required)	Single Calibration

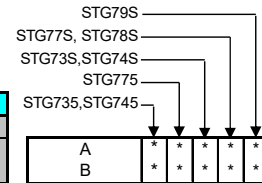

TABLE VII ACCESSORY SELECTIONS		
a. Mounting Bracket	Bracket Type	Material
	a. Mounting Bracket	None
Angle Bracket		Carbon Steel
Angle Bracket		304 SS
Angle Bracket		316 SS
Flat Bracket		Carbon Steel
Flat Bracket		304 SS
b. Customer Tag	Customer Tag Type	
	No customer tag One Wired Stainless Steel Tag (Up to 4 lines 26 char/line)	
c. Unassembled Conduit Plugs & Adapters	Unassembled Conduit Plugs & Adapters	
	No Conduit Plugs or Adapters Required	
	1/2 NPT Male to 3/4 NPT Female 316 SS Certified Conduit Adapter	
	1/2 NPT 316 SS Certified Conduit Plug M20 316 SS Certified Conduit Plug	

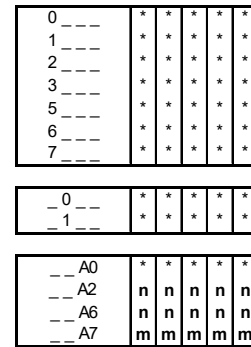

TABLE VIII OTHER Certifications & Options: (String in sequence comma delimited (XX, XX, XX,...))	
Certifications & Warranty	No additional options
	NACE MR0175; MR0103; ISO15156 Process wetted parts only
	NACE MR0175; MR0103; ISO15156 Process wetted and non-wetted parts
	EN10204 Type 3.1 Material Traceability
	Certificate of Conformance
	Calibration Test Report & Certificate of Conformance
	Certificate of Origin
	FMEDA (SIL 2/3) Certification
	Over-Pressure Leak Test Certificate (1.5X MAWP)
	Cert Clean for O <sub>2</sub> or CL <sub>2</sub> service per ASTM G93
	PM Certification <sup>5</sup>
	Extended Warranty Additional 1 year
	Extended Warranty Additional 2 years
	Extended Warranty Additional 3 years
Extended Warranty Additional 4 years	

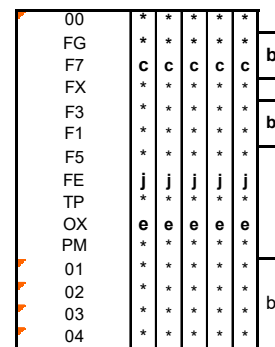
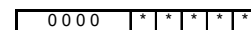

TABLE IX Manufacturing Specials	
Factory	Factory Identification



**RESTRICTIONS**

Restriction Letter	Available Only with		Not Available with	
	Table	Selection(s)	Table	Selection(s)
c	ld	___0,N,K,D___		
e	lb	__2___		
h			le	___4,5,6___
			Vla	1,2,3,5,6,7___
j			Vb	__1,2__
m	IVa	B,D,F,H___		
n	IVa	A,C,E,G___		
p			III	B- No CRN number available
t			la	J___
b	Select Only one option from this group			

<sup>5</sup> The PM option is available on all Smartline Pressure Transmitter process wetted parts such as process heads, flanges, bushings and vent plugs except plated carbon steel process heads and flanges. PM option information is also available on diaphragms except STG and STA in-line construction pressure transmitters.

**FIELD INSTALLABLE ACCESSORY KITS**

Description
Terminal Strip w/Lightning Protection Kit for HART
Terminal Strip w/o Lightning Protection for HART Modules
HART Electronics Module
HART Electronics Module w/connection for external configuration buttons
Standard Display Module

Kit Number
50129832-501
50129832-502
50129828-501
50129828-502
50126003-501

## Sales and Service

For application assistance, current specifications, pricing, or name of the nearest Authorized Distributor, contact one of the offices below.

### ASIA PACIFIC

Honeywell Process Solutions,  
(TAC) [hfs-tac-support@honeywell.com](mailto:hfs-tac-support@honeywell.com)

#### Australia

Honeywell Limited  
Phone: +(61) 7-3846 1255  
FAX: +(61) 7-3840 6481  
Toll Free 1300-36-39-36  
Toll Free Fax:  
1300-36-04-70

#### China – PRC - Shanghai

Honeywell China Inc.  
Phone: (86-21) 5257-4568  
Fax: (86-21) 6237-2826

#### Singapore

Honeywell Pte Ltd.  
Phone: +(65) 6580 3278  
Fax: +(65) 6445-3033

#### South Korea

Honeywell Korea Co Ltd  
Phone: +(822) 799 6114  
Fax: +(822) 792 9015

### EMEA

Honeywell Process Solutions,  
Phone: + 80012026455 or  
+44 (0)1344 656000

Email: (Sales)

[FP-Sales-Apps@Honeywell.com](mailto:FP-Sales-Apps@Honeywell.com)

or

(TAC)

[hfs-tac-support@honeywell.com](mailto:hfs-tac-support@honeywell.com)

### AMERICA'S

Honeywell Process Solutions,  
Phone: (TAC) 1-800-423-9883 or  
215/641-3610  
(Sales) 1-800-343-0228

Email: (Sales)

[FP-Sales-Apps@Honeywell.com](mailto:FP-Sales-Apps@Honeywell.com)

or

(TAC)

[hfs-tac-support@honeywell.com](mailto:hfs-tac-support@honeywell.com)

*Specifications are subject to change without notice.*

### For more information

To learn more about SmartLine Pressure Transmitters visit [www.honeywellprocess.com](http://www.honeywellprocess.com)  
Or contact your Honeywell Account Manager

### Process Solutions

Honeywell  
1250 W Sam Houston Pkwy S  
Houston, TX 77042

Honeywell Control Systems Ltd  
Honeywell House, Skimped Hill Lane  
Bracknell, England, RG12 1EB

Shanghai City Centre, 100 Jungi Road  
Shanghai, China 20061

[www.honeywellprocess.com](http://www.honeywellprocess.com)



34-ST-03-122  
November 2016

©2016 Honeywell International Inc.